

# WELCOME

to your Sleep Number® Bed

sleep  number®  
by SELECT COMFORT

25

60

► **Sleep Number® Bed** ◀  
assembly instructions inside



## Welcome and Congratulations,

Congratulations on your purchase of The Sleep Number Bed by Select Comfort™! You're about to join more than 6 million people who've traded their innerspring mattresses for the most innovative sleep surface ever. The technology behind the SLEEP NUMBER® bed is one that recognizes the unique sleeping needs of every individual, which vary according to comfort preference, body type, height, weight, sleeping position, and other health and lifestyle factors. By creating a fully personalized sleep surface, your new *Sleep Number* bed offers you customized comfort that can significantly improve your sleep quality.

You'll enjoy years of the latest generation of sleep comfort and technology in your *Sleep Number* bed. Our commitment to constant innovation, value and customer satisfaction has repeatedly earned us the *Consumers Digest* Best Buy award. *Sleep Number* bed owners like you have made us the No. 1 bedding retailer year after year, as ranked by *Furniture/Today*.

We thank you for your purchase and wish you years of personal comfort and restful sleep.

*William R. McLaughlin*

William R. McLaughlin

President & CEO

My Sleep Number® is 55

**Q. Why are there body impressions on the mattress cover?**

**A.** For the best looking, most crisp appearance, customers should fully inflate the mattress (100% if using a digital SLEEP NUMBER® remote). If going to full inflation does not help with body impressions in the cover, the quilted top can be removed and shaken to restore some of the loft to the fiberfill. In addition, a vacuum nozzle may be used to fluff the cover in areas where the fibers have settled from use.

Body impressions in a normal innerspring mattress would be an indication that the spring support is compressing or breaking down. The SLEEP NUMBER® bed uses air to support your body. Since air cannot break down, you receive the same support after years of use as you do on the first day of use.

**Q. The wireless pump remote is displaying “Er.” What is the problem?**

- A.** An “Er” can be caused by several factors. The Firmness Control™ System base may not have power, or the remote and Firmness Control™ System base may have lost communication with one another.
- Make sure the Firmness Control™ System is firmly plugged into a working outlet and is receiving power. Is the outlet controlled by a wall switch? You will know that the unit has power if it “clicks” when you plug it in.
  - Make sure that the power cord is plugged into the side of the Firmness Control™ System.
  - Wait for the display to shut off (about 10 seconds). Then try to adjust the bed again. But this time, move the remote control a few inches to the left or right.
  - If the “Er” persists call Customer Service at the number on the back cover.

**STILL NEED HELP?**

If you still have questions or need assistance, look for answers on our Web site [sleepnumber.com](http://sleepnumber.com) or please call Customer Service at the number on the back cover.

Dear QVC Customer,

Congratulations! We are delighted that you purchased the SLEEP NUMBER® bed. We know you will enjoy your *Sleep Number* bed for many years!

QVC and SLEEP NUMBER® are committed to providing exceptional service to you. To provide that priority service, we have established the *Sleep Number*® GOLD SERVICE program with a phone number, 1.800.790.9298, exclusively for QVC customers. This number will allow you to quickly reach a SLEEP NUMBER® representative.

These *Sleep Number* representatives are product specialists who are able to answer any questions you may have regarding setup, finding your SLEEP NUMBER® setting, manufacturer's warranty details, or any other product-related questions—including comfort tips.

When you call, please have your QVC Order Number readily available.

*Sleep Number* representatives are available Monday through Friday, 8 a.m. to 6 p.m. CST and Saturday, 8:30 a.m. to 5 p.m. CST. You can also visit the SLEEP NUMBER® Customer Web site at [mygoldservice.com](http://mygoldservice.com), where you will find assembly information, troubleshooting FAQs and warranty information.

For all other questions, please contact QVC Customer Service at 1.800.367.9444 or visit [qvc.com/customerservice](http://qvc.com/customerservice). Thank you for your purchase. QVC and *Sleep Number* look forward to serving you in the future.

Best Regards,

Dan McDermott  
Senior Vice President  
Customer Services, QVC

Brooks Goldade  
Vice President  
Commercial and Partner Sales,  
Select Comfort



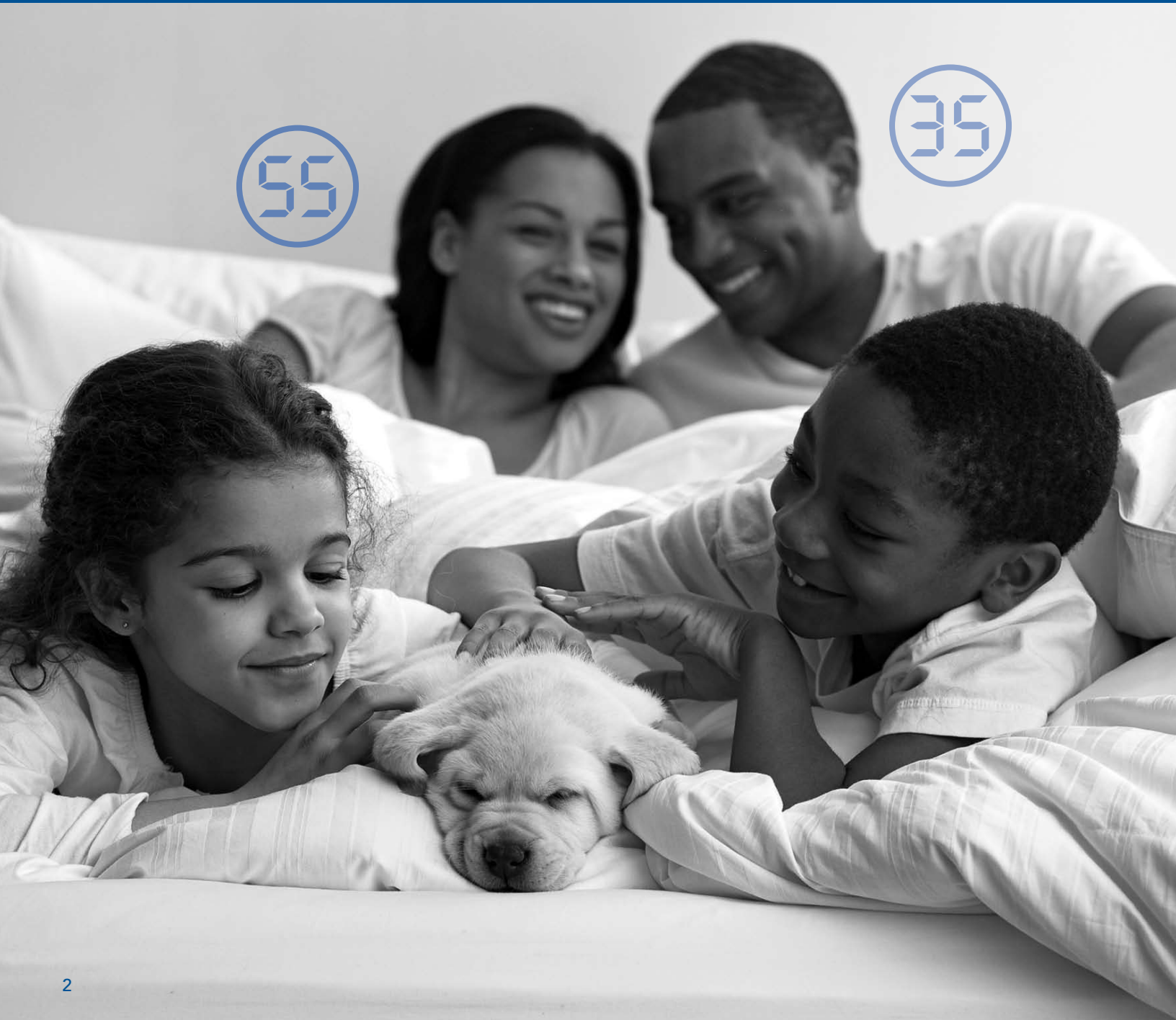



# WHAT'S inside

Setting up your new SLEEP NUMBER® bed only takes about an hour, but you'll enjoy the benefits of better sleep for years to come. You won't need any tools and, although it's nice to have a helper, you can do it by yourself. First, you'll need to remove your old bed. Next, we'll guide you step-by-step through assembling the foundation, positioning the mattress and attaching the Firmness Control™ System. Then, you'll learn how to find your SLEEP NUMBER® setting. And, finally, the best part—you can luxuriate in the personalized comfort of your *Sleep Number* bed.

- ▶ Foundation Assembly ..... pg 4
- ▶ Mattress Assembly..... pg 10
- ▶ Firmness Control™ System ..... pg 18
- ▶ FCC Users Information..... pg 20
- ▶ Mattress Care..... pg 22
- ▶ Warranty..... pg 24
- ▶ Frequently Asked Questions..... pg 26

# FOUNDATION

## assembly

If you are missing any items listed on the following page, please e-mail Customer Service at [customerservice@selectcomfort.com](mailto:customerservice@selectcomfort.com) or call the number on the back cover.

### TROUBLESHOOTING

For answers to some common questions regarding your foundation, see the Frequently Asked Questions at the end of this manual.

“ I assembled the Sleep Number bed by myself. My wife was in doubt at first, but, after sleeping one night, she said, it was magic how well she slept without back pain. Now we sleep longer and more comfortably than with any previous mattress we've owned. ”

- C. Clark S., Tucson, AZ

### BEFORE YOU BEGIN

- ▶ **Carefully check the contents of your foundation boxes**
- ▶ **Decide where to put your new bed**
- ▶ **Make sure there's an electric power source nearby for use with your Firmness Control™ System**
- ▶ **Assemble your bed frame if you have one**

Your foundation should be assembled directly onto your bed frame or on the floor. Some bed frames have slats that run from one side of the bed to the other. If your bed frame has slats, position the slats evenly to support the foundation. If your bed frame has fewer than three slats, we recommend adding additional slats to ensure adequate support for your foundation.

Caution: With some styles of bed frames, the foundation length may extend beyond the frame's support legs. This situation makes it possible for the frame to tip when significant weight is placed at the foot of the bed. Please use caution when sitting or placing weight on the foot of the bed when using these types of frames.

#### ▶ **King foundation**

The King foundation consists of two Twins side by side. Complete the assembly of one unit, assemble the second, then place side by side on the bed frame.







Note: Texture and surface appearance may vary.

sleep  number.  
by SELECT COMFORT

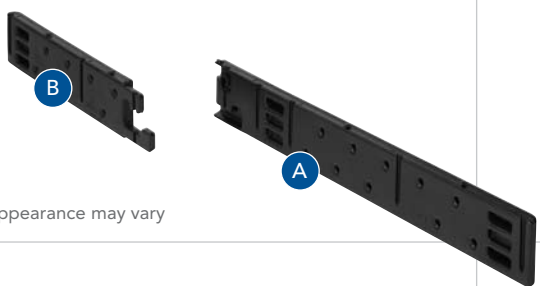
# CONTENTS

Carefully check the contents of your foundation boxes and compare with the list below. Each component is clearly labeled with the part name and part number.

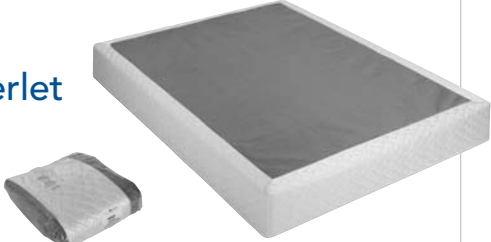
		QUANTITY		
		Full	Queen	King
 <p><b>Side Rails</b> Texture and surface appearance may vary</p>	2 each	2 each	4 each	
 <p><b>Support /End Beams</b> Texture and surface appearance may vary</p>	6	6	12	
 <p><b>Deck Panels</b> Texture and surface appearance may vary</p>	4	4	4	
 <p><b>Pin Components</b></p>	2	2	4	
 <p><b>Fabric Coverlet</b> Packaged in the mattress box Shown as packaged</p>	1	1	1	



# FOUNDATION

## assembly

### 1 CONNECT SIDE RAILS

Push the components labeled A side rail and B side rail together.

*Joints fit tightly. Push firmly.*

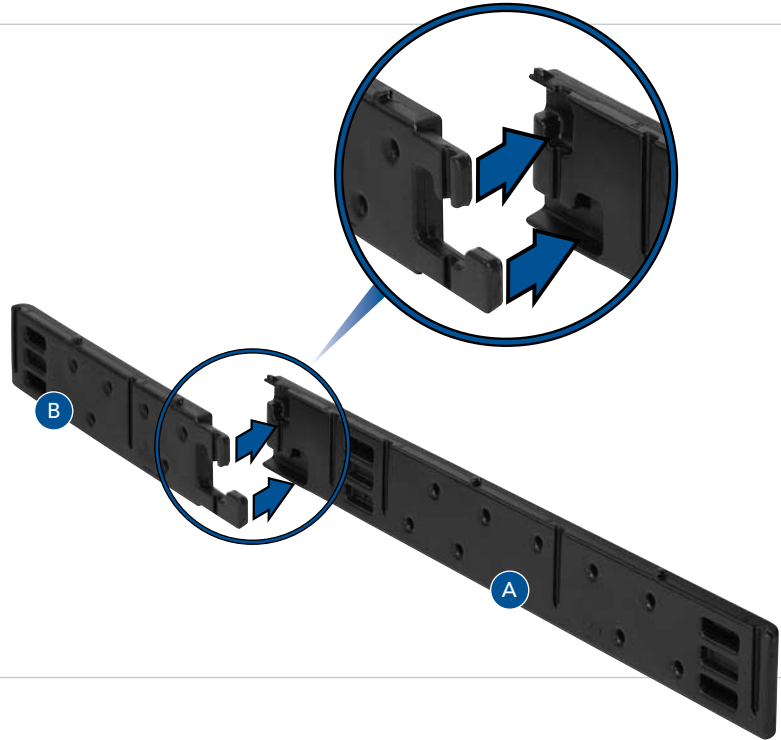

### 2 INSERT PIN

Slide pins in, "T" end up.

*Push firmly.*

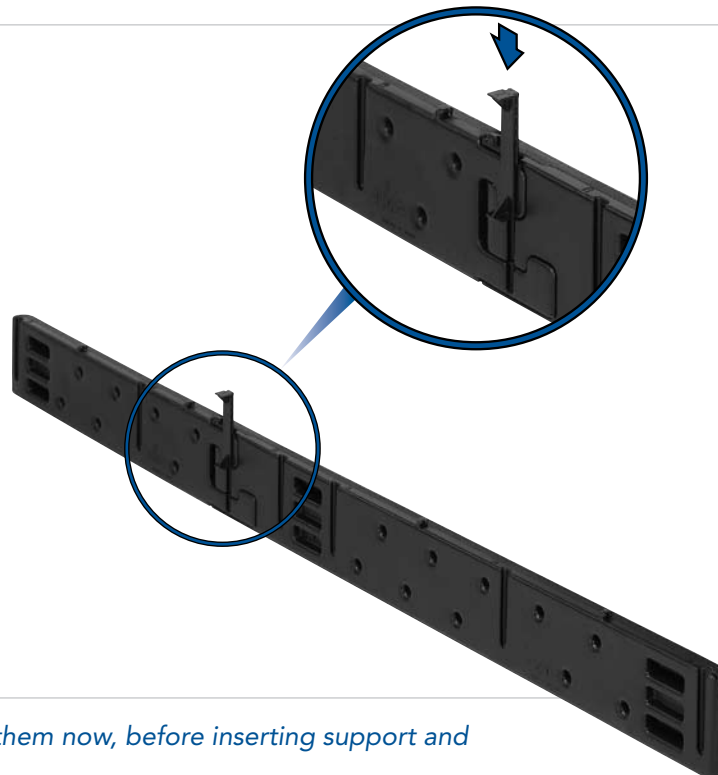

*If you've purchased foundation legs, install them now, before inserting support and end beams. (See package for instructions.)*

### 3 INSERT SUPPORT/ END BEAMS

For Twin, Queen and  
Eastern King beds:

- insert support beams  
with tabs up and textured  
side out.

For Full and California  
King beds:

- insert labeled end beams  
followed by remaining  
support beams with tabs up.

*Joints fit tightly. Push firmly  
until top is flush.*

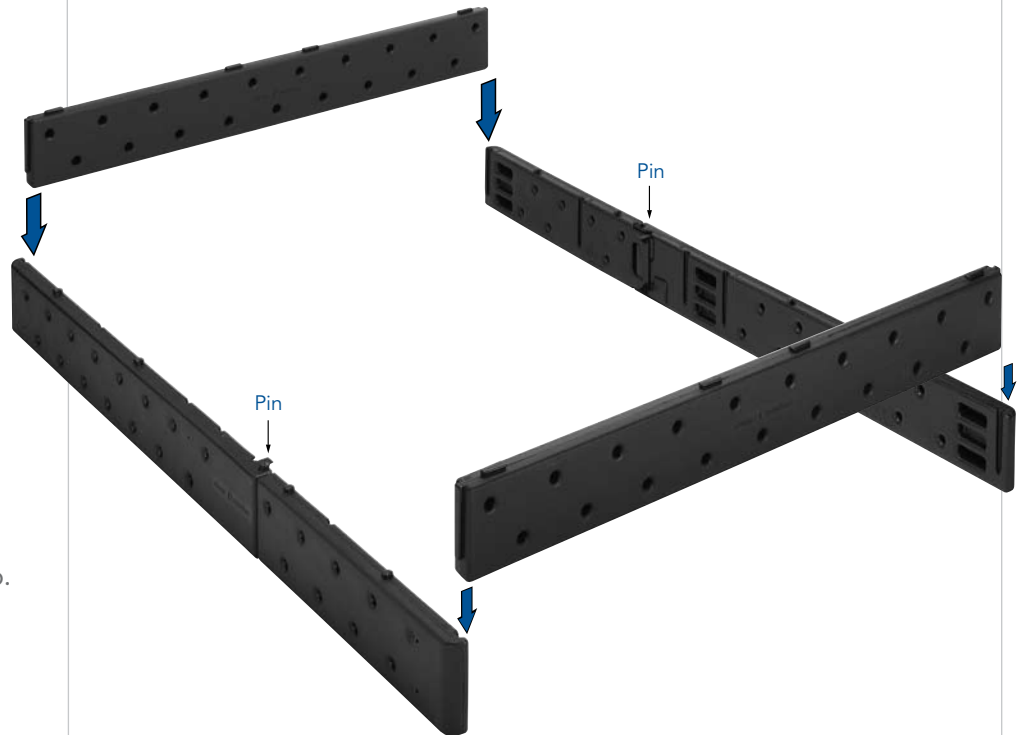

# FOUNDATION assembly

4

## INSERT SUPPORT BEAMS

Tab up, match "A" end with "A" groove; match "B" end with "B" groove.

*Joints fit tightly, push firmly until top is flush.*

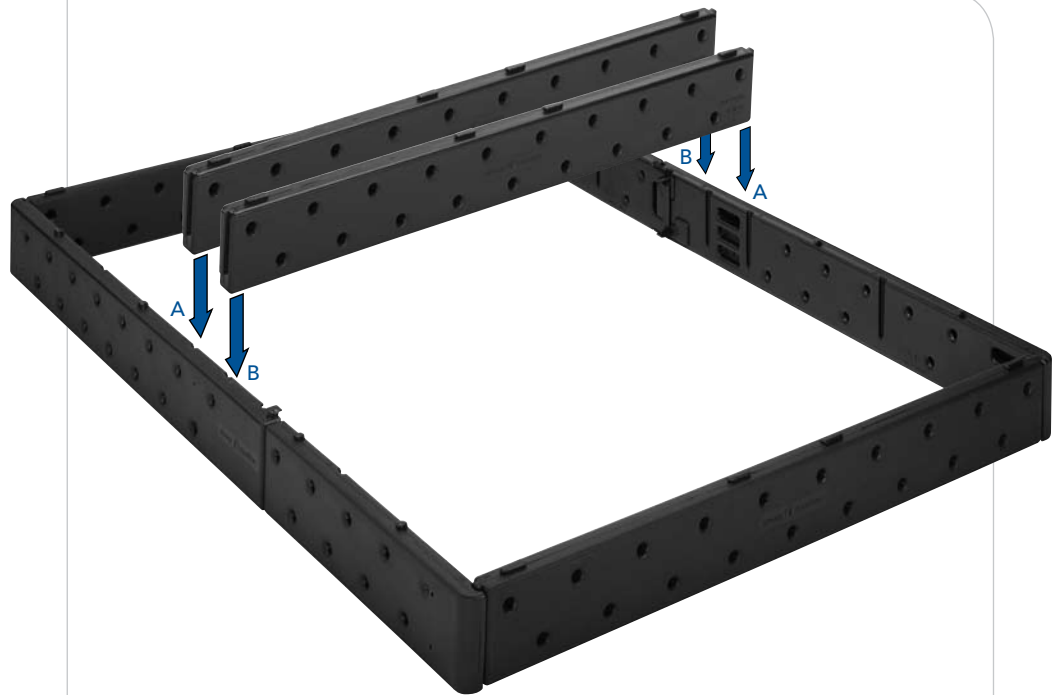

Slide the remaining support beams into the next set of channels.

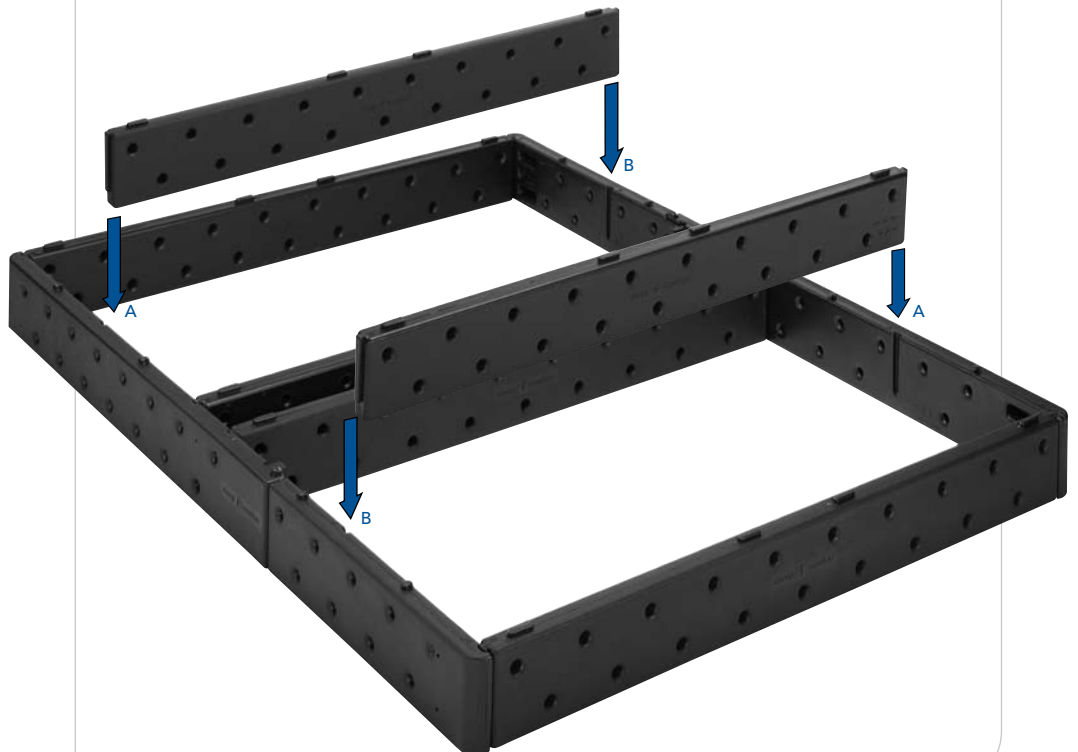

## 5 PLACE DECK PANELS

Slide panels in until they are flush on sides.

*Panels fit snugly, do not force.*

*Reminder*  
King foundation consists of two  
Twins side by side.

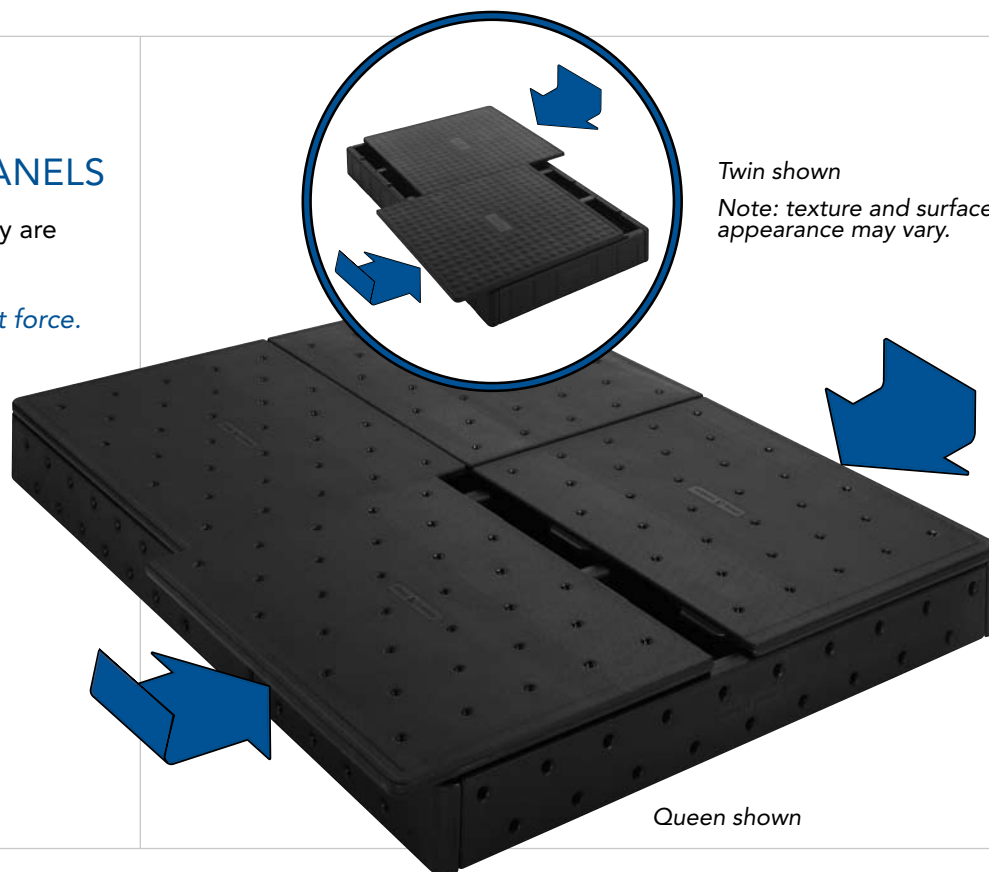

## 6 PUT ON COVERLET

Work on carefully, one corner at a time, positioning seam at head of bed.



**YOU'RE DONE! NEXT STEP ► MATTRESS ASSEMBLY**

# MATTRESS assembly

If you are missing any items listed on the following page, please e-mail Customer Service at [customerservice@selectcomfort.com](mailto:customerservice@selectcomfort.com) or call the number on the back cover.

## TROUBLESHOOTING

For answers to some common questions regarding your mattress, see the Frequently Asked Questions at the end of this manual.

“This is the first time in three years that I slept through the entire night without getting up two or three times. I’m thrilled and amazed! Unbelievable! I wish we had purchased your sleeping system years ago.”

- Keith F., Jackson, MI

## BEFORE YOU BEGIN

- ▶ **Carefully check the contents of your mattress boxes**
- ▶ **IMPORTANT NOTE Prepare your foam pad**

Carefully open the foam comfort pad and set aside.

**At least 20 minutes of expansion time is needed.**

- ▶ **Orientation**

These instructions refer to “left” and “right” as if you are standing at the head of the bed looking toward the foot of the bed.

- ▶ **Using a Surge Protector**

While the Firmness Control™ System may be plugged directly into a wall outlet, we recommend using a surge protector to guard against unexpected power surges. We recommend using a surge protector that is listed to UL® 1449 with a clamping voltage of 330 volts, and a joule rating of 700 or higher.

Please note: Your 20-Year Limited Warranty does not cover damage to the Firmness Control™ System due to a power surge, regardless of the source. See the Limited Warranty for more details.



sleep  number.  
by SELECT COMFORT

# CONTENTS

Carefully check the contents of your mattress boxes and compare with the list below. Each component is clearly labeled with the part name and part number.

Single Chamber

Dual Chamber

## QUANTITY

		Full Single Chamber	Queen Dual Chamber	King Dual Chamber
<p><b>Mattress Cover</b></p> <p>Color and pattern will vary by bed</p> <p>Shown as packaged</p> 		1	1	1
<p><b>Foam Border Walls</b></p> <p>Two long and two short</p> 		4	4	4
<p><b>Corner Lock™ System</b></p> <p>Shown as packaged</p> 		4	4	4
<p><b>Air Chambers</b></p> 		1	2	2
<p><b>Firmness Control™ System with Remotes</b></p> <p>Remote will vary</p> 		1	1	1
<p><b>Center Foam Wall</b></p> <p>Dual Chamber beds only</p> 		0	1	1
<p><b>Foam Comfort Pad</b></p> <p>Color and pattern may vary</p> <p>Shown as packaged</p> 		1 memory 1 zoned	2 memory 2 zoned	2 memory 2 zoned

# MATTRESS assembly

REMEMBER: Open the foam comfort pad before you begin and let expand for 20 minutes.

## 1 POSITION MATTRESS COVER

Place on foundation or on existing bed platform.

*Make sure the holes in the bottom of the cover are at the head of the bed.*

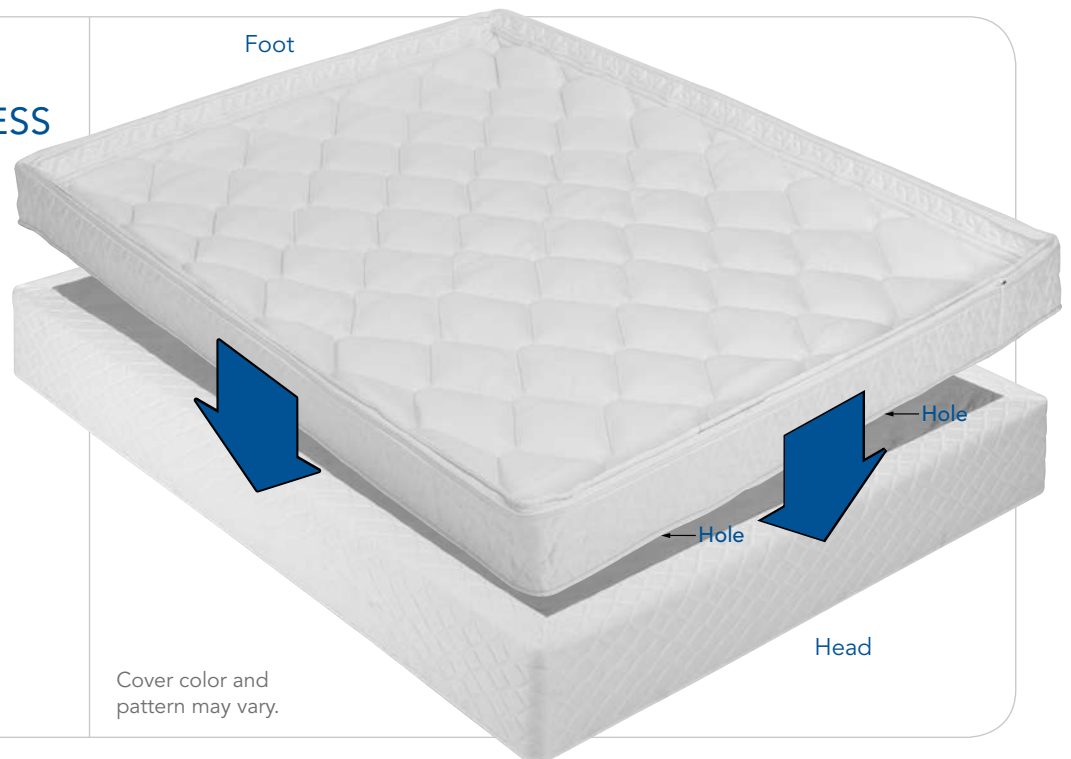

## 2 UNZIP MATTRESS COVER

Set cover aside.



### 3 PLACE CORNER LOCKS

Place one in each corner.

*Corner locks must go under the border wrap.*



### 4 INSTALL FOAM BORDER WALLS

Place long border walls along sides, extending the entire length of the bed.

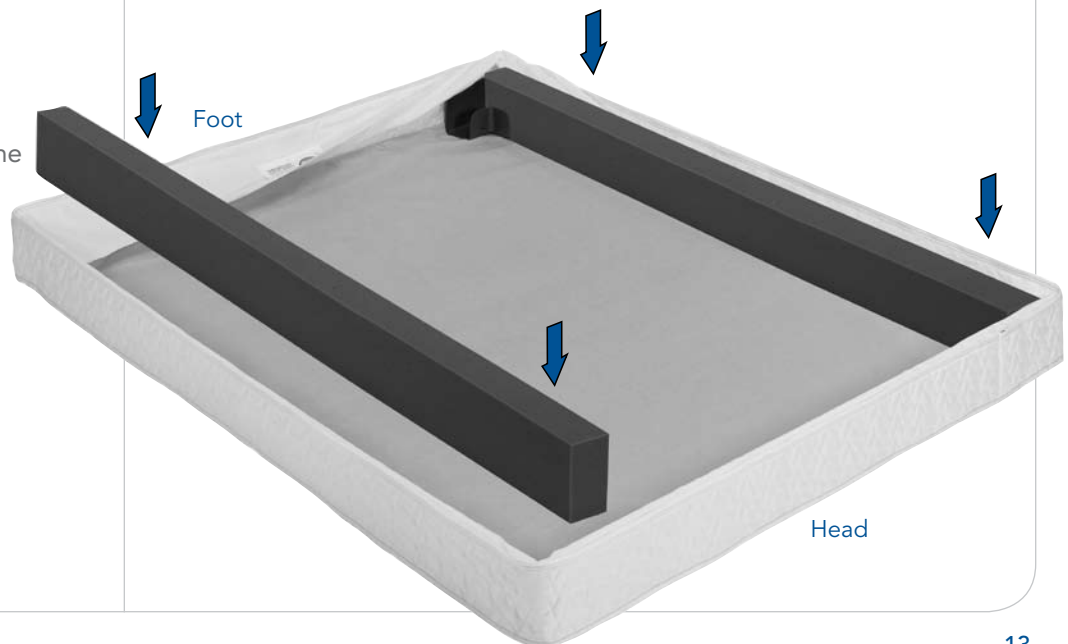



# MATTRESS assembly

## 5 INSTALL FOAM BORDER WALLS

Place short border walls at the head and foot, between the side walls.



*Make sure the foam border walls are connected securely and squarely. The border wrap should cover the foam border walls.*

## 5 INSTALL AIR CHAMBERS

Place air chambers so the hose connectors face the head of the bed, and lay on bottom when inflated.

*If air chambers are not zipped together, zip both the bottom and top edges together.*

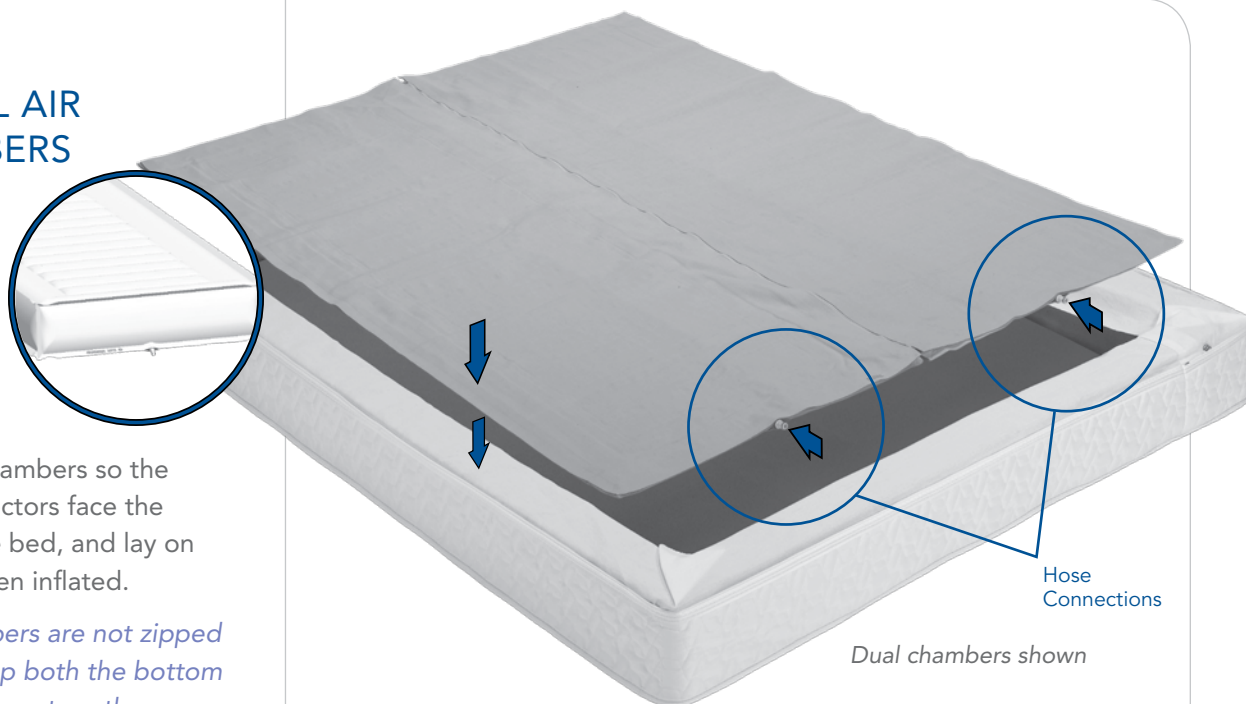

## 1 CONNECT FIRMNESS CONTROL™ SYSTEM

Place the Firmness Control™ System on the floor at the head of the bed. Plug the power cord into the Firmness Control™ System and into an outlet.

### Key Step:

Pass the hose marked "L" through the hole on the left side of the mattress cover and connect to the left air chamber.

Press hose connections together until they click.

Then complete the right side.

**IMPORTANT SAFETY NOTICE:** The warranty does not cover damage to the Firmness Control™ System due to a power surge. Using a surge protection device (not included) is recommended.

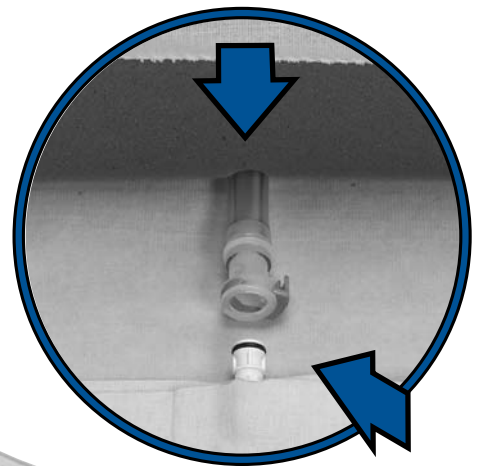

Store air chamber caps inside mattress at head of bed.

# MATTRESS assembly

## 8 INFLATE AIR CHAMBER(S)

Using remote, inflate air chamber.

*For dual chamber beds,  
repeat for second air chamber.*



Insert center foam wall: Unzip top air-chamber zipper, insert foam between chambers, zip closed.

### IMPORTANT SAFETY NOTICE:

Position the border wrap over foam border walls and air chambers as shown.

For dual chamber models, press "L" or "R" to activate and select a side.

Press the ▲ button several times to inflate to "20."

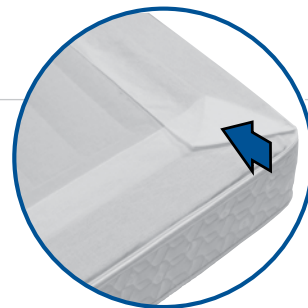
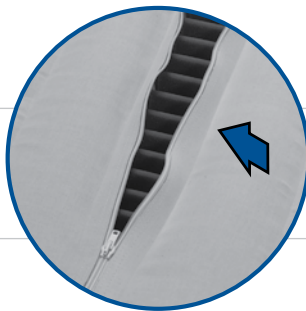

## 9 INSTALL FOAM COMFORT PAD

Place the memory foam on top for a more plush surface, or the Intralux® foam for a more firm surface.

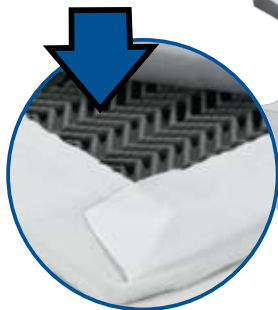

### IMPORTANT SAFETY NOTICE:

Make sure the patterned side is up. Then extend the border wrap over the foam comfort pad as shown.

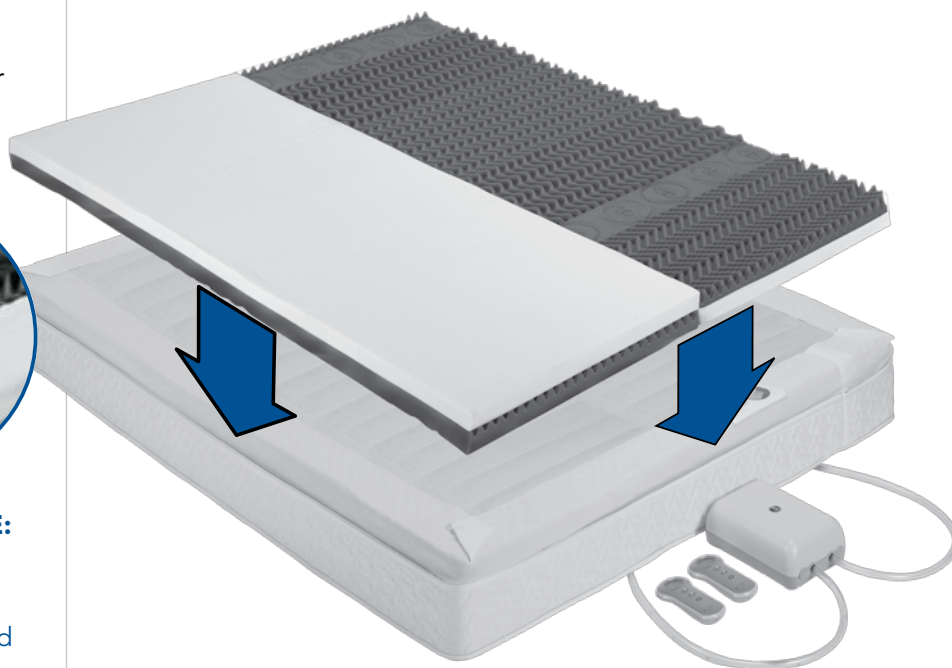

Foam color and pattern may vary.

## 10 VERIFY BORDER WRAP POSITIONING

Verify that the border wrap extends over the foam comfort pad.

**IMPORTANT SAFETY NOTICE:** To ensure compliance with federal and state flammability requirements, the border wrap must be positioned correctly within the mattress as shown.



## 11 MATTRESS COVER

Zip the top of the mattress cover.



Color and pattern may vary.

**YOU'RE DONE! NEXT STEP ►  
THE FIRMNESS CONTROL™ SYSTEM**

# FIRMNESS Control™ System

If you are missing any items listed on the following page, please e-mail Customer Service at [customerservice@selectcomfort.com](mailto:customerservice@selectcomfort.com) or call the number on the back cover.

## TROUBLESHOOTING

For answers to some common questions regarding your Firmness Control™ System, see the Frequently Asked Questions at the end of this manual.

“I had forgotten what it feels like to wake up feeling good and with energy. Sleeping on the Sleep Number bed has made a big difference. Thank you for making me feel good again.”

- Vicky H., Hartford, KY

## THINGS TO REMEMBER

### ► Reasons to alter the firmness of your bed

- strained muscles
- back pain
- weight change
- pregnancy
- sunburn
- new sleep position

### as well as

- to facilitate getting out of bed, if needed
- to achieve a fuller bed appearance

### ► Dual Adjustability

If you purchased a dual chamber bed, you have the ability to personalize each side of your SLEEP NUMBER® bed. Since no two body types are the same, each sleep partner should find their own comfort level.

If your bed came with one remote for a dual chamber bed, the “L” button on the remote corresponds to the left side of the bed (left is determined when lying on your back on the bed). The “R” button corresponds to the right side.



sleep  number.  
by SELECT COMFORT

## WHAT IS A SLEEP NUMBER® SETTING?

Your SLEEP NUMBER® setting is a number between 0-100 that represents the ideal combination of mattress comfort, firmness and support for your body, giving you the best night's sleep possible.

## YOUR SLEEP NUMBER® SETTING

When you shopped for The Sleep Number Bed by Select Comfort™, you may have discovered your *Sleep Number* setting. You should use this as a starting point when setting the firmness of your SLEEP NUMBER® mattress. If you don't have your *Sleep Number* setting, this section will take you through the process of finding your *Sleep Number* setting and will provide you with additional information about your SLEEP NUMBER® bed. If you don't already have your *Sleep Number* setting or if you would like to experiment with finding a different *Sleep Number* setting, use the instructions below.

## EVALUATING YOUR COMFORT LEVEL

As you are customizing the *Sleep Number* bed for your optimum comfort level, you will want to evaluate your sleep position and determine how you feel as compared to the diagrams below, then make adjustments to your firmness or pillow if needed. Your pillow should help keep your body aligned properly, otherwise it may interfere with your ability to sleep comfortably. Visit [sleepnumber.com](http://sleepnumber.com) or one of our stores to get fit for a perfect pillow and see the extensive selection of innovative pillows we carry for all sleep positions and fill preferences.

### RIGHT



- Neck and back are aligned in the same position as when you are upright.
- No discomfort at shoulder and hip pressure points.
- You feel the mattress support the small of your back (back sleepers) or the curve of your side (side sleepers).

### WRONG



- Body alignment is not straight.
- Your pillow makes your head tilt at an angle to the rest of your body.
- You feel discomfort from pressure at your neck, shoulders, back, hips or legs.

## GIVE IT TIME

It sometimes takes several nights of sleeping at different settings to discover your ideal *Sleep Number* setting. If you would like to experiment further with your *Sleep Number*, you may want to consider keeping a sleep journal. When you have found a *Sleep Number* setting where you feel comfortable, log this number into your sleep journal. Try to sleep at this *Sleep Number* setting for three to four nights, adjusting in increments of 5 or 10 only. It will take your body that long to become accustomed to a new sleep surface. After five nights, reevaluate your comfort level and log the new setting into your sleep journal, adding comments if helpful. Repeat the process until you have found the perfect setting for you.

*If, after trying four different Sleep Number settings, you have not found your ideal Sleep Number setting and would like additional assistance, go to [sleepnumber.com](http://sleepnumber.com) and click on Customer Center or call the number on the back cover to reach a Customer Service Representative. Our trained Customer Service Representatives may be able to recommend adjustments, make suggestions or pinpoint concerns that might be contributing to less than ideal comfort. Improving your sleep is our expertise.*

# FIRMNESS Control™ System

## IDENTIFY YOUR REMOTE AND ITS FUNCTIONS

### Single Chamber



wakes when any button is pressed

### Dual Chamber



wakes when L or R button is pressed

*For wireless remotes:  
A 9-Volt battery is included and should last about six months under normal use. Replace the battery when the low battery indicator is displayed.*

BUTTON	FUNCTION
Firmer ▲ Softer ▼	Press and <b>release</b> the ▲ or ▼ button several times until the desired SLEEP NUMBER® setting is displayed. Adjustments will begin after a slight delay.
Side (L) and (R)	Press to choose a side, it will display the previous <i>Sleep Number</i> setting.
Memory	<p>This feature allows you to set your favorite <i>Sleep Number</i> setting into memory and recall it at any time.</p> <p><b>SETTING MEMORY</b></p> <ul style="list-style-type: none"> <li>- Press L or R to choose a side and wake up the remote.</li> <li>- Adjust the bed to the <i>Sleep Number</i> setting you'd like as your memory setting.</li> <li>- Press and hold the Memory button for 3 seconds.</li> <li>- "Memory Set" will appear above the <i>Sleep Number</i> when it's set.</li> </ul> <p><b>RECALLING MEMORY</b></p> <ul style="list-style-type: none"> <li>- Press L or R on the side you would like to recall.</li> <li>- Press the Memory button 2 times within 5 seconds.</li> </ul> <p><i>The first press of the button will display the current Sleep Number set in memory. The second press of the button will adjust the bed to the memory setting. As the adjustment is taking place, the number displayed and tick marks will indicate the change.</i></p>

\*Caution Statement: (per CFR 15.21) Changes or modifications not expressly approved by the party responsible for compliance could void the users authority to operate the equipment.

Device Statement: (Section 15.105 (b) of the FCC Rules) \*Note: This equipment has been tested and found to comply with the limits, pursuant to part 15 of the FCC Rules. These limits are designed to provide reasonable protection against harmful interference in a residential installation. This equipment generates, uses, and can radiate radio frequency energy and, if not installed and used in accordance with the instructions may cause harmful interference to radio communications. However, there is no guarantee that interference will not occur in a particular installation. If this equipment does cause harmful interference to radio or television reception, which can be determined by turning the equipment off and on, the user is encouraged to try to correct the interference by one or more of the following measures:

- Reorient or relocate the receiving antenna.
- Increase the separation between the equipment and receiver.
- Connect the equipment into an outlet on a circuit different from that to which the receiver is connected.
- Consult the dealer or an experienced radio/TV technician for help.

This device complies with Part 15 of the FCC Rules. Operation is subject to the following two conditions: (1) this device may not cause harmful interference, and (2) this device must accept any interference received, including interference that may cause undesired operation.

#### Important Safety Instructions

- **WARNING**—To reduce the risk of fire or electric shock, do not use this Firmness Control™ System with any solid-state speed control device.
- No user serviceable parts are included. For service needs, contact Select Comfort Customer Service.
- Protect the Firmness Control™ System against water ingress.
- Certain Firmness Control™ Systems have a polarized plug (one blade is wider than the other). To reduce the risk of electric shock, this plug is intended to fit in the polarized outlet only one way. If the plug does not fit fully into the outlet, reverse the plug. If it still does not fit, contact a qualified electrician. Do not attempt to defeat this safety feature.

## FINDING YOUR SLEEP NUMBER® SETTING

### ► Step 1

- Lie on one side of the SLEEP NUMBER® bed in your normal sleep position, holding your remote.

### ► Step 2

- Evaluate your comfort level.

### ► Step 3

- If you have a dual chamber bed with a “L” and “R” button, press one to choose a side.

### ► Step 4

- Tap the firmer or softer button until it reaches your desired comfort setting and let the bed adjust. Repeat until you have reached your ideal level of comfort. Your new SLEEP NUMBER® setting will be displayed.

### ► Step 5

- Try this *Sleep Number* setting for a minimum of five nights, then reevaluate and make adjustments accordingly.

### NOTE

When setting or checking your *Sleep Number* setting you must be lying on the bed in your normal sleep position. If you are off the bed or not in your normal sleep position, you will see variations in your *Sleep Number* setting.

## One Bed, Two Sleep Number® settings

Because most couples disagree on mattress firmness, the *Sleep Number* bed adjusts on both sides. You can each find your ideal comfort level—your *Sleep Number* setting—at the touch of a button.

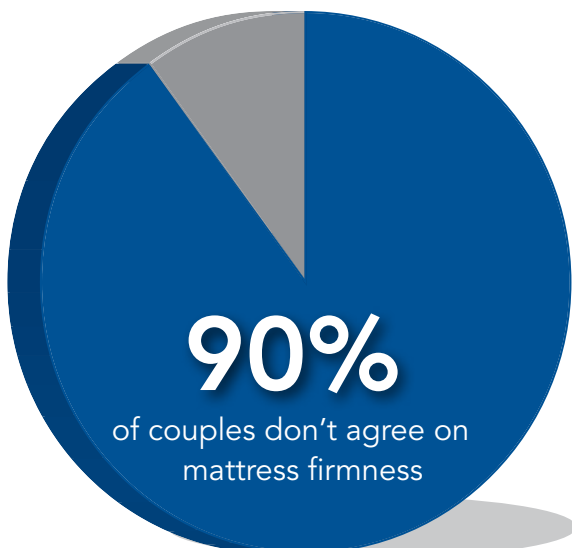

## Sleep Number® setting study

As you can see, *Sleep Number* bed owners find comfort at all settings from 0–100, however the majority of sleepers find their *Sleep Number* setting between 35–50.

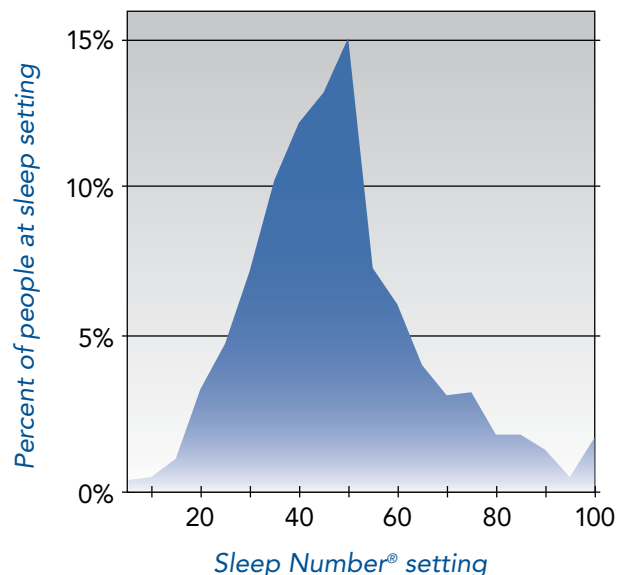



# MATTRESS

## care

### TROUBLESHOOTING

For answers to some common questions regarding your mattress, see the Frequently Asked Questions at the end of this manual.

### MATTRESS CARE

The cover of your SLEEP NUMBER® mattress may be spot cleaned with carbonated water. Do not dry clean the mattress cover or put it in a washing machine. Also, please do not apply stain guard, as it may cause yellowing of the fabric.

Select Comfort is a leader in the industry in the use of materials designed to inhibit the growth of allergens or microorganisms that, in rare circumstances, can form inside any mattress, bedding, pillow or upholstered product.



“I bought my Sleep Number bed nine years ago and it has been the smartest purchase I’ve ever made. Every single night, I sleep in ultimate comfort.”

- Thao T., Sugar Land, TX

sleep  number.  
by SELECT COMFORT

Advanced antimicrobial safeguards are incorporated into every SLEEP NUMBER® bed. Key components of the mattress have been treated to protect the bed from contaminants such as mold, mildew and bacteria growth. The unique, zip-open design of the *Sleep Number* bed allows you to easily open, ventilate or vacuum if you choose.

In rare instances under the right conditions, mold or mildew can form inside many types of mattresses, bedding or upholstered products. Should this condition occur in your mattress, please contact our customer service department so we can work with you to return your bed to factory-fresh condition.

## TRANSPORTING YOUR SLEEP NUMBER® BED

Your *Sleep Number* bed is lighter than any conventional bed, making it much easier to move.

### Moving it yourself

- The foundation should always be disassembled. Bag all hardware so that it is not lost.
- If you have a full-size mattress moving box, the mattress can be fully inflated, capped off and packaged.
- If you don't have a mattress box, the cover and foam should all be double bagged to prevent stains. The chambers should be deflated and boxed to prevent possible abrasions and other damage.
- The Firmness Control™ System should be packed in a box, surrounded by some sort of packing material if the original box is not available.
- The remote, caps and instructions should be tucked in the box with the pump to prevent them from being lost.

### Using a moving company

- The foundation should always be disassembled. Bag all hardware so that it is not lost.
- The mattress can be fully inflated, capped off, and should be packaged in a mattress box for moving.
- The Firmness Control™ System should be packed in a box, with packing material, and transported in a manner where it will be exposed to minimal shock and vibration.

## CREATING A HEALTHY SLEEP ENVIRONMENT

An estimated 50 million Americans suffer from allergies, and the bedroom presents some especially difficult challenges. A few simple steps you can take to create a healthy sleep environment include:

- Use a dehumidifier to reduce any potential mold or mildew growth. Keep humidity levels under 60 percent.
- Use a high-quality mattress pad to protect your mattress from moisture. You may want to consider a waterproof mattress pad if you perspire heavily while sleeping.
- Use allergen covers on pillows and mattresses to reduce dust mites, which can trigger allergies and asthma. Wash bedding weekly in hot water.
- Vacuum the bedroom regularly, using a high quality vacuum cleaner such as one with a HEPA filter, one that does deep cleaning, or a central vacuum system.
- Wait 20-30 minutes before making your bed each morning, turning the covers back and allowing the mattress to air out for a bit.
- If possible, avoid placing your bed on an outside wall or above an air conditioning or heating vent, which can cause condensation and increase the likelihood of mold growth in many mattresses.
- You could also use a high-quality electronic air purifier to remove additional airborne particulates from the bedroom.
- Please note: Ozone generators ARE NOT recommended for use in the same room with the *Sleep Number* bed, as they can degrade components of the bed over time.

# WARRANTY

“We love our bed. Now all of our friends are getting Sleep Number beds and they love them too. I just received an email from a friend who purchased a King Sleep Number bed and finally found relief from his back pain. What more can we say than ‘Thank You’ for this fabulous product. We’ll never stop recommending your beds.”

- Jolie C., Homewood, IL

## RETURN POLICY

We hope you are completely satisfied with your SLEEP NUMBER® bed, but if you are not, contact QVC. They will be able to provide you with further details.

## DEFECTIVE OR DAMAGED COMPONENTS

If any component of the mattress or foundation is found to be defective in materials or workmanship within first two years of the original purchase date, they will be replaced by Select Comfort at no cost to you. Within the first two years, all shipping charges to replace a defective component will be covered by Select Comfort. If any component of the mattress or foundation is found to be defective in materials or workmanship after two years from the original purchase date, the terms of the Limited Warranty will apply. After two years from the date of purchase, you will be responsible for the cost of shipping the defective component back to Select Comfort and any related costs. Contact our Customer Service Department at the number on the back cover for troubleshooting assistance and if you need to process the replacement order.

We recognize that components may break, become soiled or unusable and may not be covered under the warranty. In the event that replacement components are required or if you wish to upgrade to newer components, you may purchase these items by simply providing proof of purchase. All component sales are final and carry a 2-Year Limited Warranty from the purchase date. Product discounts and accessory promotions do not apply to components. Call our Customer Service department for current pricing and to process the component purchase.

## LIMITED WARRANTY

### What is covered:

- Select Comfort provides a limited warranty for your mattress and/or foundation. The limited warranty provides protection from defects in materials and workmanship for a period of 20 years from the original purchase date. Warranty is limited to product repair or replacement only.

### What we will do:

- Select Comfort, at its option, will repair or replace the warranted product or component at a cost to the original purchaser based on the following table. The "price" is the price of the warranted product or component at the time the warranty claim is made, or the price of a comparable product or component if the original product or component is no longer in production.

Years after purchase date	Original purchaser's cost
Up to 2 years	No Cost
2-20 years	20% plus 4% of price for each year from original purchase date.

- For example, if a warranty claim arises 12 years after the original purchase date, the cost to the original purchaser would be 68% of the price (that is, 20% plus 4% for each of the 12 years) and Select Comfort would be responsible for the remaining 32% of the price.
- Select Comfort reserves the right to substitute products or components of equal or better quality, and to use or deliver refurbished products or components in the repair or replacement of any product under this Limited Warranty.

### What is not covered:

- Conditions arising from normal wear and tear. (Conditions arising from normal wear and tear include, but are not limited to: mattress cover compression, foam compression, or discoloration of components.)
- Damage from tampering with any component or from opening the Firmness Control™ System.
- Damage from misuse or abuse of the warranted product or component.
- Damage from laundering or dry-cleaning.
- Acts of God, such as but not limited to lightning damage.

### What you must do:

- Return the warranted product or component in sanitary condition to an authorized SELECT COMFORT® service center. Select Comfort will incur the cost of shipping up to two years after the original purchase date; after two years, the return shipping to Select Comfort will be at the customer's expense.
- Please telephone our Customer Service Department at the

number on the back cover to locate the nearest authorized service center and arrange for the return of the warranted product or component.

### What will void this warranty:

- Tampering with any component or opening the Firmness Control™ System and its hand control unit.
- Misuse or abuse of the warranted product or component.
- Sale, transfer or other disposal of the warranted product or component.

### Limitations:

- Your exclusive remedy, IN LIEU OF ALL INCIDENTAL, SPECIAL OR CONSEQUENTIAL DAMAGES, INCLUDING FOR NEGLIGENCE, is limited to repair or replacement of any product or component deemed to be defective under the terms and conditions stated above. Select Comfort will bear no other damages or expenses.
- Customer maintains responsibility for installation of parts replaced under terms of the warranty.
- Select Comfort reserves the right to refuse to repair or replace any product or component that is returned in an unsanitary condition.
- Warranty for exterior surfaces against stains and soil is limited to manufacturer's defect only, within the first 30 days of delivery. No other warranty coverage against stains and soils is included.
- This Limited Warranty applies only to the product as used in the United States and Canada. It is not applicable in U.S. territories or other countries.
- This Limited Warranty is non-transferable.
- Repair or replacement of a product or component under the terms of this Limited Warranty in no way lengthens the Limited Warranty period.
- ANY IMPLIED WARRANTIES APPLICABLE TO THIS PRODUCT, INCLUDING ANY WARRANTIES OF MERCHANTABILITY OR FITNESS FOR A PARTICULAR PURPOSE, ARE LIMITED IN DURATION TO THE DURATION OF THIS WRITTEN LIMITED WARRANTY.

Some states do not allow the exclusion or limitation of incidental or consequential damages, or limitations on how long an implied warranty lasts, so the above limitations may not apply to you. This warranty gives you specific legal rights and you may also have other rights, which vary from state to state.

All claims relating to the Limited Warranty of Select Comfort products should be made by contacting Customer Service at the number on the back cover or writing to Select Comfort Customer Service, 6105 Trenton Lane North, Minneapolis, MN 55442.

# FAQ'S

## frequently asked questions

“I've had my bed for one week and I just love it. I sleep better than I have in years. I love that you can adjust the softness or firmness. I wake up refreshed with little or no back pain.”

- Judy O., Lewisville, KY

### FOUNDATION FAQ'S

#### Q. What if I can't get my center support beams flush with the side rails?

A. Make sure the letter on the center support beam matches the side rail. For example, the end of the center beam labeled "A" should connect to the side rail with the "A" on it. Additional force may be required.

#### Q. How can I get my pins in all the way?

A. All pins are wider at one end and narrower at the other end. Make sure the "T" end is up and the narrow end goes into the side rail first. You may need to use a bit of force to get it in place.

#### Q. What can I do if I can't get the deck panels to lay flat?

A. First, make sure all the pins and beams are flush. Then, set the deck panel over the notches. You should then be able to slide the panel into place.

#### Q. Where is the hardware for the footboard and headboard brackets?

A. The same hardware for attaching the legs to the foundation is used for attaching the brackets. Align the bracket with the holes for the leg bolts. Attach the leg per the instructions.



## MATTRESS FAQ'S

### **Q. Where are the caps for air chamber(s)? And where should I store them?**

**A.** The caps are in the Firmness Control™ System box. Please store these in the mattress cover in case you should ever want to disassemble your bed and temporarily cap your air chamber(s).

### **Q. What if my foam comfort pad appears to be too small or irregular?**

**A.** Gently shake the pad as you place it on your mattress and it will recover its full size overnight.

### **Q. What do I do if the Firmness Control™ System doesn't run?**

**A.** Make sure the power cord is securely plugged into the Firmness Control™ System and the wall outlet. Check to see if the power cord is plugged into an outlet that has power and is not connected to an on/off wall switch.

### **Q. What if I feel like I'm rolling toward the edge or toward the center of the mattress?**

**A.** Although rare, these sensations could potentially be experienced if one side of the mattress is set quite firm and the other side quite soft. Call Customer Service for a remedy to this situation if it is bothersome to you.

### **Q. What if I notice a rubber smell from the air chamber?**

**A.** The odor you may smell is non-toxic and will fade over time. To minimize the smell, unzip the mattress cover and allow the air chamber to air out for a few hours. Laying a couple of dryer sheets on top of the air chamber will also help mask any odor by adding a fresh scent.

### **Q. Will my bed deflate if there is a power surge or power loss?**

**A.** No, your mattress will maintain its firmness. To protect your Firmness Control™ System, we do recommend using a surge protector.



## STILL NEED HELP?

If you still have questions or need assistance, look for answers on our Web site [sleepnumber.com](http://sleepnumber.com) or please call Customer Service at the number on the back cover.

# FAQ'S

## frequently asked questions

“We have had our Sleep Number bed for several years now. It has been very comfortable and has held up well for all these years.”

- Kathey Y., Summerville, SC

### Q. Why does my Sleep Number® setting change?

- A.** There are several factors that can contribute to fluctuations in a SLEEP NUMBER® setting. A Sleep Number setting is based on the combination of body weight, volume of air in the air chamber and sleep position.
- Temperature: An increase or decrease in temperature can cause changes in a Sleep Number setting. A heated mattress pad will cause the Sleep Number setting to increase.
  - Barometric Pressure: Changes in atmospheric pressure related to weather and altitude can cause your Sleep Number setting to change.
  - Weight: The Firmness Control™ System acts similarly to a scale; more weight means a higher Sleep Number setting. In addition, the way that the weight is distributed will affect the reading.
  - Sleep Position: The more concentrated the weight is, the greater chance the Sleep Number setting will be higher (i.e., when you lie on your side). When it is distributed throughout the chamber more, it is more likely that the Sleep Number setting will be lower (i.e., when you lie on your back or stomach).

### Q. The mattress seems to be losing air. What should I do?

- A.** The air loss could be due to a loose connection or caused by either the air chamber or the Firmness Control™ System. First, make sure the hoses are connected securely to the air chambers. Press the hose connections together firmly until they click. If an air loss is still suspected follow the instructions below.
- Inspect the o-ring and connectors for cracking or damage—reconnect the pump to the air chamber making sure that the connector snaps into place.
  - Fill the bed to your normal Sleep Number setting plus an additional 15 (i.e., if you sleep at 35, fill to 50) while lying in your normal sleep position. We ask that you over inflate to allow for air that will escape while you are capping the air chamber. **NOTE:** When setting or checking your Sleep Number setting you must be lying on the bed in your normal sleep position. If you are off the bed or not in your normal sleep position, you will see variations in your Sleep Number setting.
  - Remove the hose from the air chamber and cap the air chamber quickly.
  - Leave the air chamber capped for a minimum of 48 hours.
  - If air chamber becomes noticeably softer, contact Customer Service. If not, reconnect the pump to the air chamber and continue to use the bed. Repeat troubleshooting steps if the mattress continues to consistently lose air, this time leave the air chamber capped for seven consecutive nights.



# HELP IS JUST a click or phone call away.

If you ever have product questions or need additional assistance obtaining optimal comfort, please visit us at:

[sleepnumber.com](http://sleepnumber.com)

or call

**1.800.790.9298**

Representatives are available (Central Standard Time):

Monday–Friday 8am – 6pm

Saturday 8:30am – 5pm

Sunday Closed

**FPO**



113899

08/09

sleep  number<sup>®</sup>  
by SELECT COMFORT

6105 Trenton Lane North, Minneapolis, Minnesota 55442