

How to set up your new Sleep System.

Ultra Series

Pillowtop and Traditional Models



SELECT COMFORT[®]
The Air Bed Company

**If you have any questions or are in need of any
assistance, please contact Customer Service at**

1-800-472-7185.

Components of your Select Comfort Ultra Sleep System:

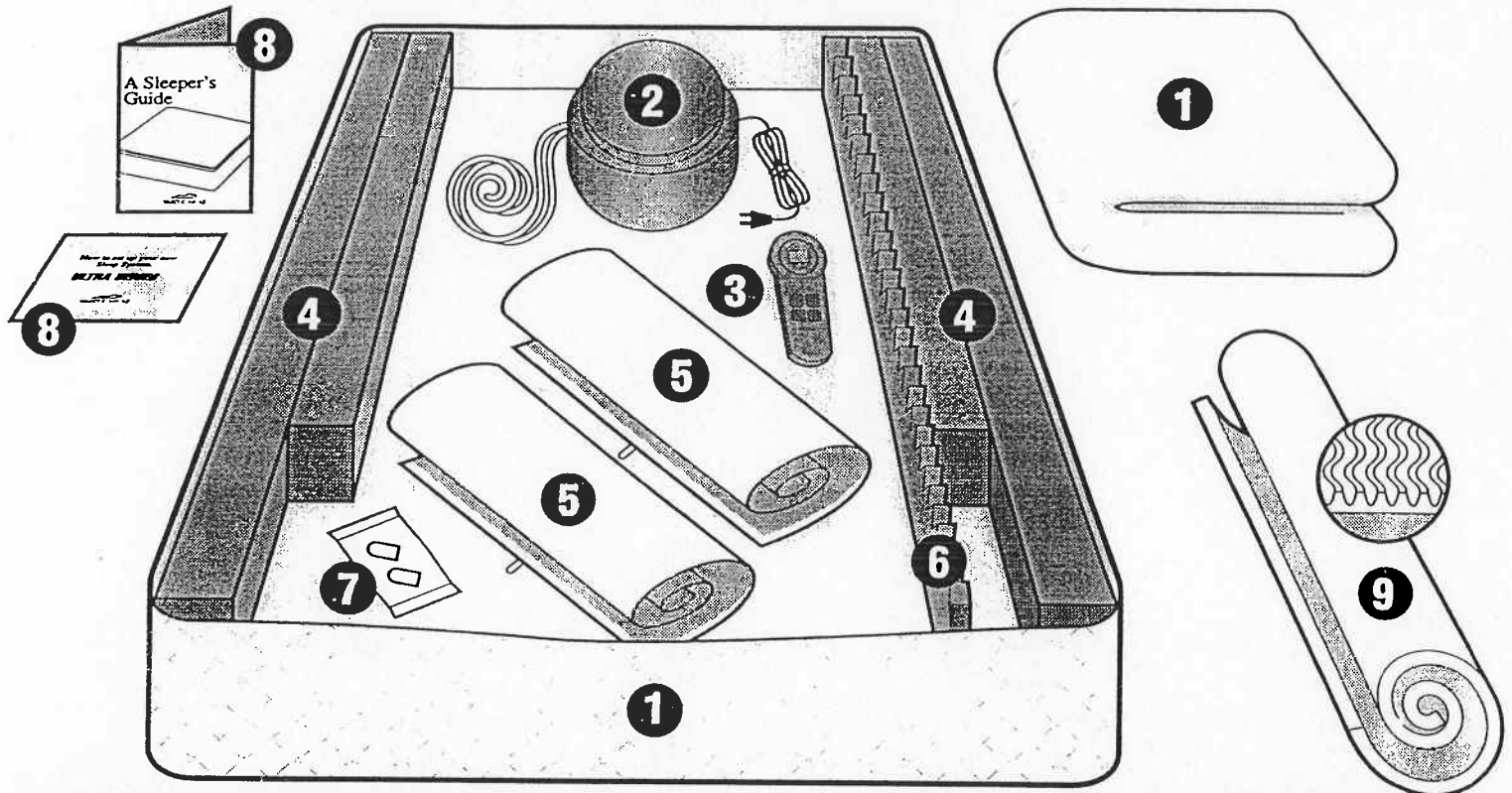

STEP-BY-STEP GUIDE

- 1 Mattress Cover (2 parts zipped together)
- 2 Firmness Control System (FCS)
- 3 Remote Control with 9 volt battery installed
- 4 Foam Border Walls (2 long, 2 short)
- 5 Air Chamber(s) (2 for dual chamber model; 1 for single chamber model)
- 6 Center Foam Wall (for dual chamber model only)
- 7 Caps for Air Chamber(s) (package of 2)
- 8 A Sleeper's Guide and Set-Up Instructions

And for Pillowtop Model only:

- 9 Foam Comfort Pad (1)

Functions of the Remote Control

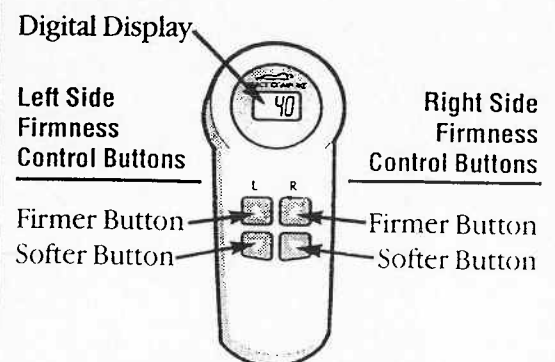

Note: For single chamber model, use only the right side firmness control buttons

Select Comfort Ultra Series Sleep System

1

*Zipped to the
Pillow top.*

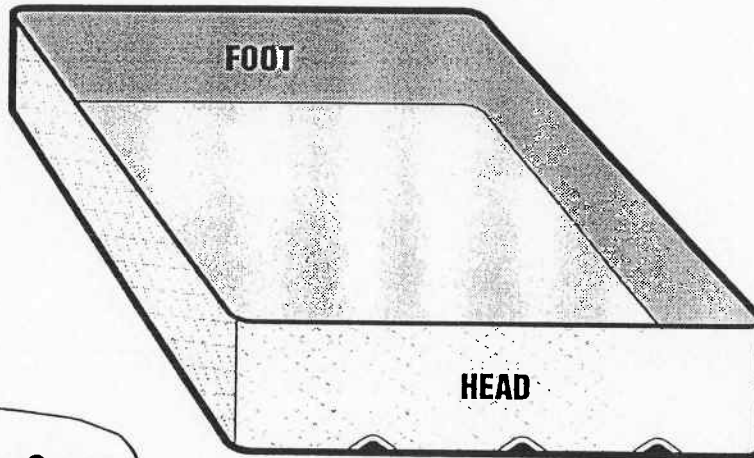

Position the Mattress Cover

- Place the Mattress Cover (quilted side up) on top of the foundation (or bed platform).
- Unzip the top portion of the cover and set it aside.
- Position the cover so that the holes in the underside of the cover are at the head of the bed.

2

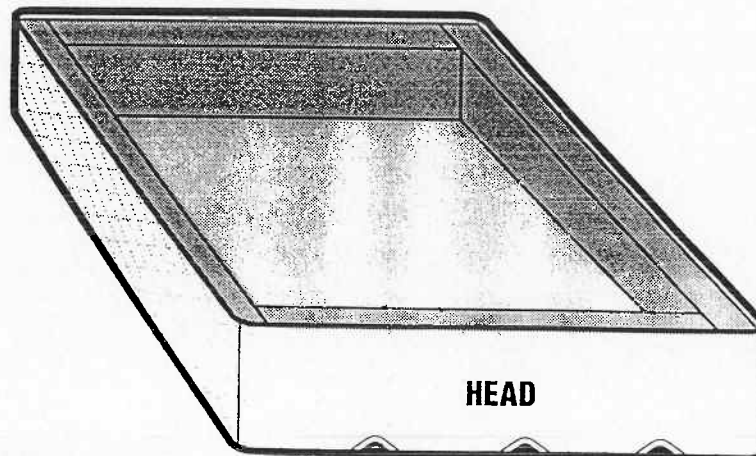

Insert the Foam Border Walls

- Place the two long Foam Border Walls along the sides of the mattress cover with the velcro pads facing inward and the zippers facing downward.
- Place the shorter Foam Border Walls at the head and foot of the bed with the zippers facing downward.
- Connect the velcro pads securely and squarely.

3

Install the Air Chamber(s)

- Lay the Air Chamber(s) inside the mattress cover so that the Hose Connector(s) are on the bottom and face the head of the bed. The connector(s) will roughly align with the small openings at the base of the mattress cover.

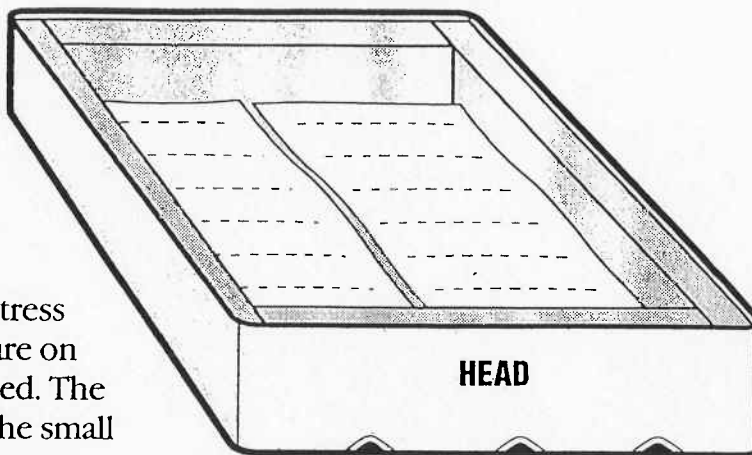

(dual chamber model shown)

4

Connect the Firmness Control System

- Place the Firmness Control System (FCS) on the floor at the head of the bed and plug into an electrical outlet. The unit will "beep" for 1 second, indicating that it is receiving power.
- Take each hose and pass the end through the small opening at the base of the mattress cover, under the Foam Border Wall, and connect it to the corresponding chamber. The Select Comfort product label will be placed at the foot of the bed. (For dual chamber models, the top hose of the FCS works with the right chamber; the bottom hose works with the left chamber.)

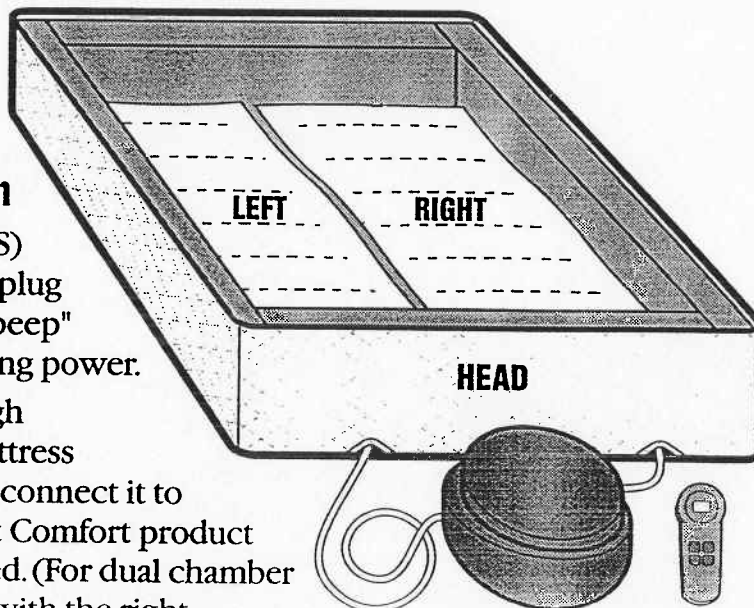

Hint: To ensure a solid connection, press together until they "click."

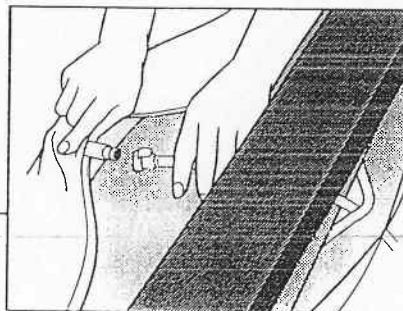
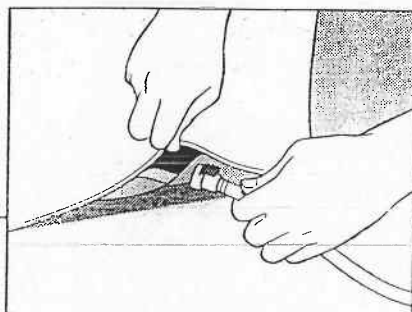

5

Inflate the Air Chamber(s)

- Press the right side "firmer" button on the Remote Control to wake up the FCS. As the Remote Control and Base Unit establish contact, the display will blink several times.
- When the display stops blinking, set the firmness to "20" and the chamber will begin inflating. (The first time you fill each chamber, it may take about 15 minutes or more. The FCS shuts itself off after 10 minutes, so simply set the firmness to "20" again to reactivate the pump and complete the initial fill.)
- If you have the dual chamber model, once the first chamber has finished inflating repeat for second. Then insert the Center Foam Wall between the chambers, centering it between the head and foot.

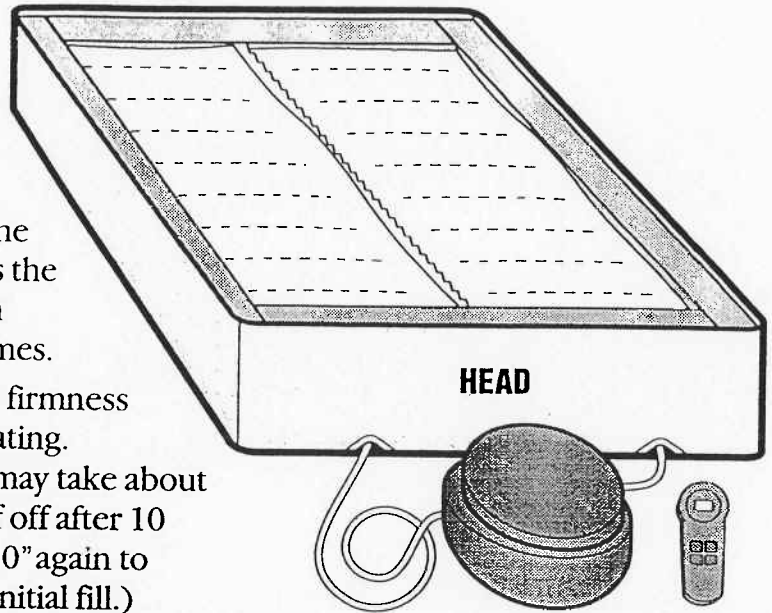

6

*If you purchased a
Pillowtop Model Mattress ...*

Install the Foam Comfort Pad

- Place the Foam Comfort Pad on top of the Air Chamber(s) with the "zones" facing up. The end with the clipped corners should be at the head of the bed. The pad should rest neatly on top of the chamber(s), nesting inside the Foam Border Walls.

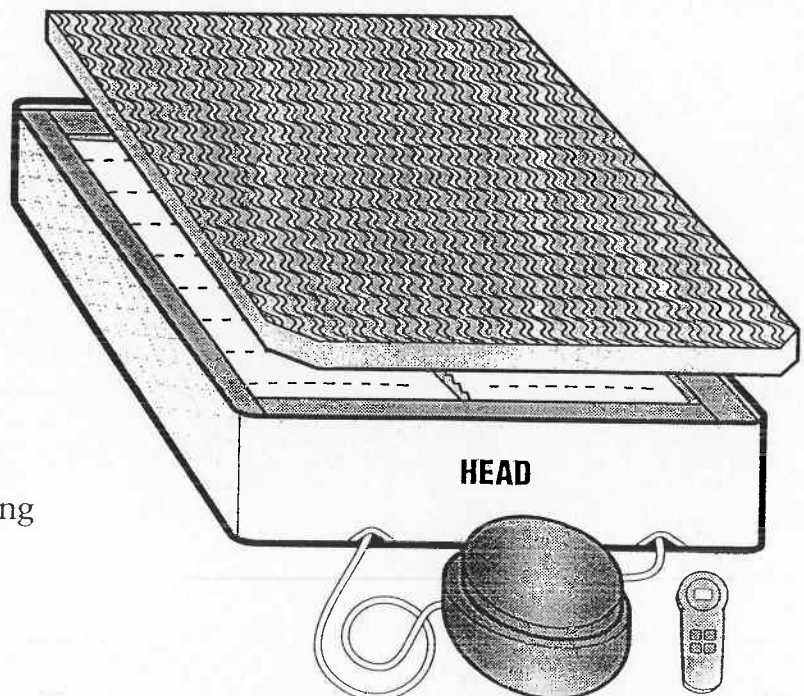

7

Pillowtop Model

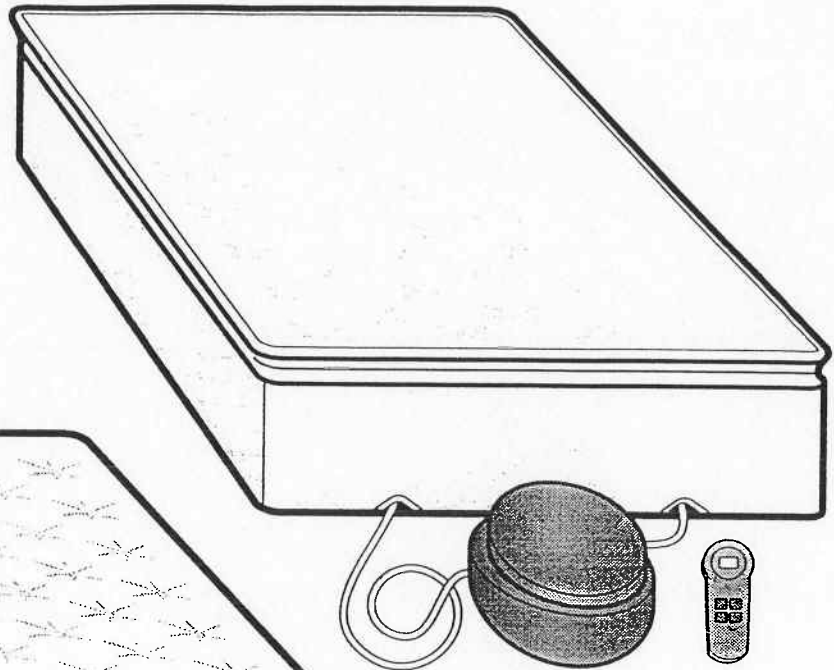

Traditional Model

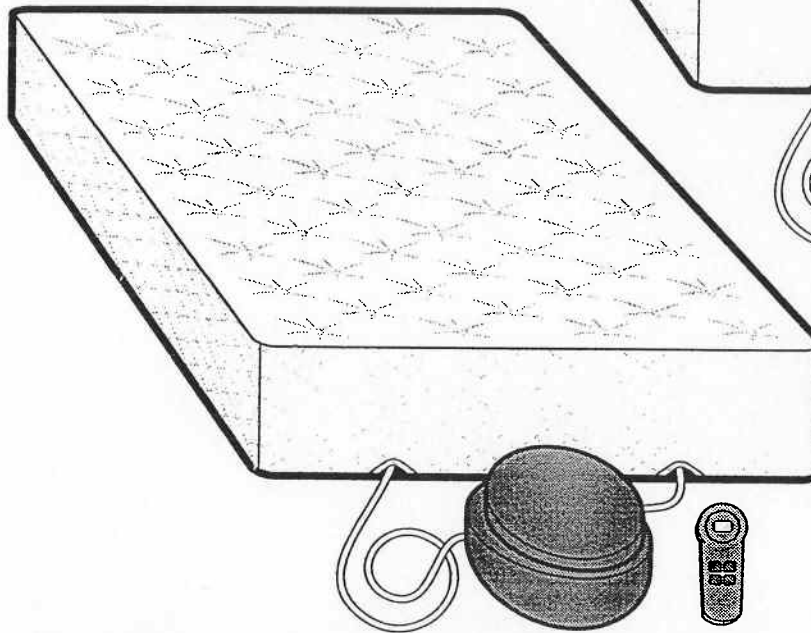

Final Steps

- Zip on the top of the Mattress Cover.
- Move the bed to your desired location.
- Arrange the FCS underneath the bed, making sure the hoses are not crimped.

That's it! You're done.

Be sure to read "A Sleeper's Guide," which explains how to adjust mattress firmness and provides other user information. And have a good night's sleep!

Components of Your Select Comfort Elite, Ultra and Imperial Foundation

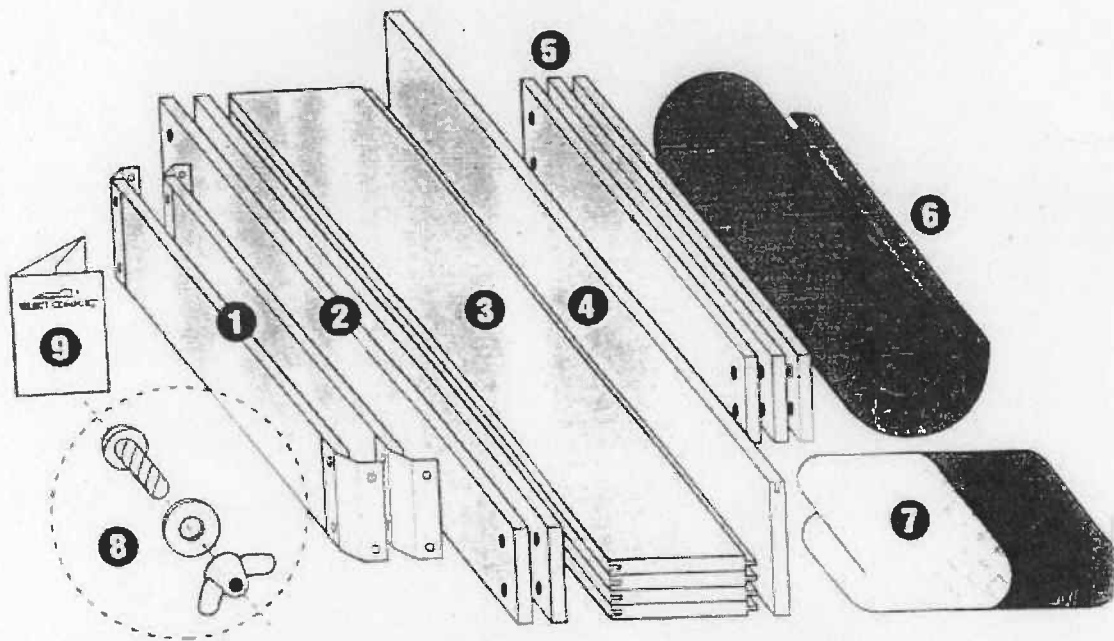

- ❶ End Planks (2)
- ❷ Side Planks (2)
- ❸ Deck Panels (2 for Twin size,
4 for Full and Queen size,
5 for King size)
- ❹ Partial Deck Panel
- ❺ Center Planks (3)
- ❻ Foam Topper Pad
- ❼ Coverlet
- ❽ Hardware
 - Carriage Bolts (20)
 - Washers (8)
 - Wing Nuts (20)
- ❾ Set-up Instructions

1

Connect End Planks to Side Planks

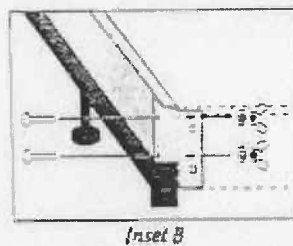
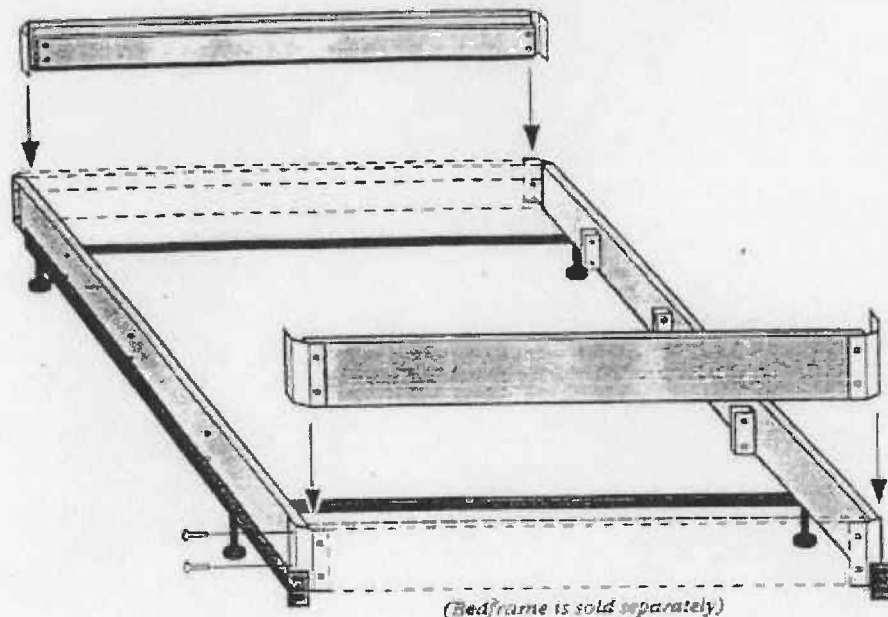

- Place the two Side Planks on the rails of bedframe, with the open portions of the "U brackets" facing upward.
- Take the two End Planks and identify the "deep shelf" end of each plank (see inset A).
- With the "deep shelf" ends facing upward, fasten the End Planks to the Side Planks, using the carriage bolts, washers and wing nuts (see inset B).

2 Insert Center Planks

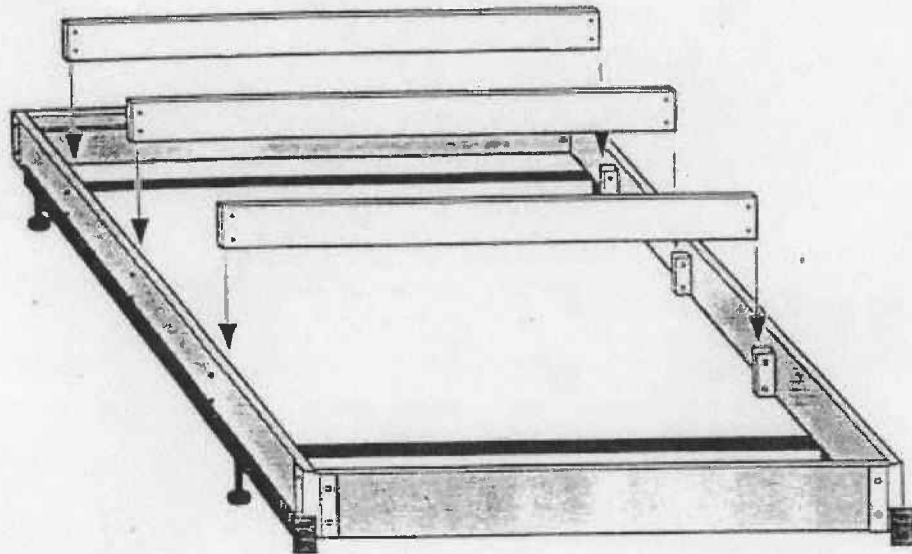

- Slide each of the three Center Planks into the corresponding U brackets on the Side Planks.
- Fasten the Center Planks to the U brackets using carriage bolts and wing nuts, and tighten to hand-tightness. Ensure that the bolt head on each bolt is fitted correctly into the square holes in the bracket.

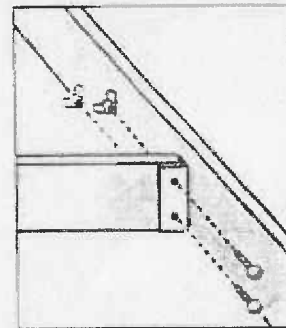

Note: Washers are not required for connecting Center Planks to the U brackets.

3

Place Deck Panels into Frame

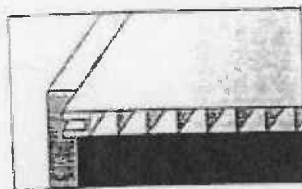
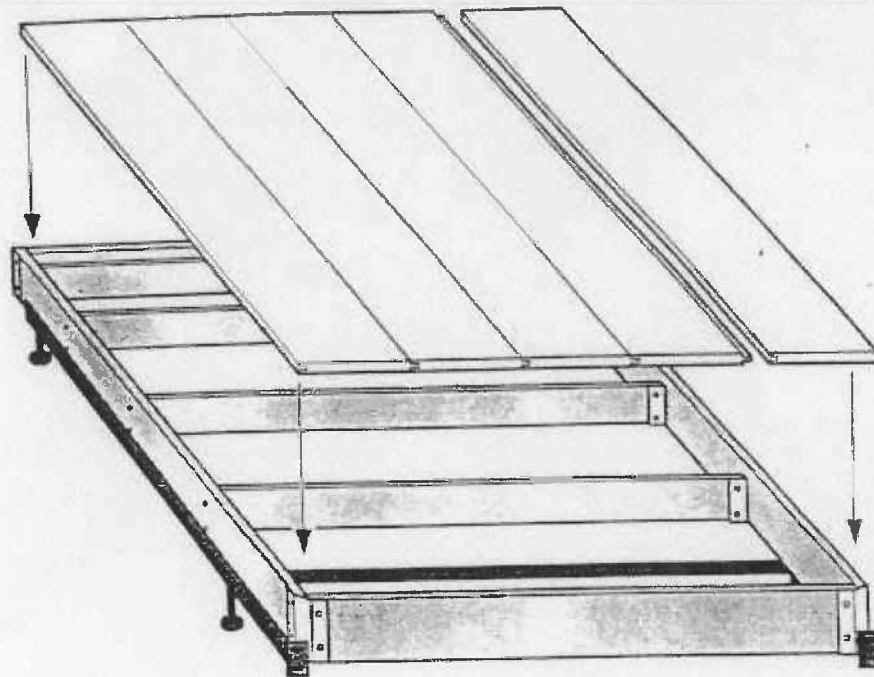

Inset A

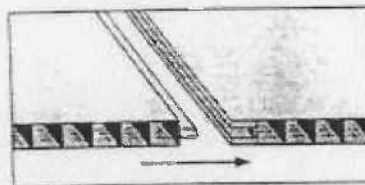

Inset B

- Identify the Partial Deck Panel (grooved on one side, but no "tongue" on the other side) and set it aside. You will use this panel last.
- Then, place any Deck Panel on top of the Center Planks with the grooved side against the Side Plank. (See inset A)
- Next, place the remaining Deck Panels on top of the Center Planks with tongue and groove interlocked. (See inset B)
- Last, place the Partial Deck Panel with the grooved side interlocked with the tongue of the previously placed Deck Panel.

Note: The number of Deck Panels required will vary according to the size of your foundation. Queen size assembly shown.

4

Install Foundation Topper Pad

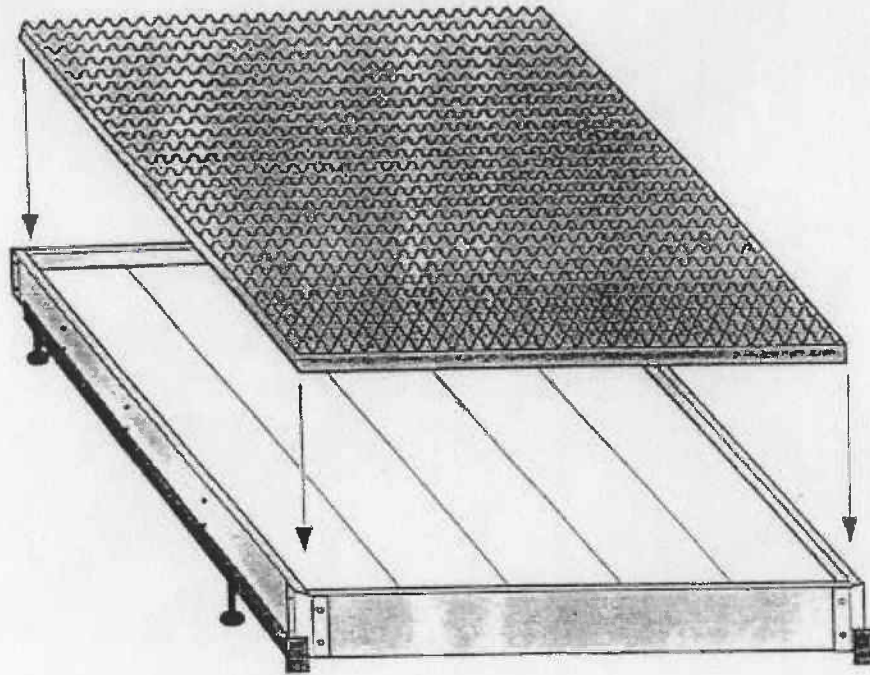

- Take the Foam Topper Pad and position it with the smooth side against the Deck Panels.

Note: Due to the vacuum packing process, the Foam Topper Pad initially may be smaller than the deck panel surface and may be somewhat irregularly shaped. Center the pad on the Deck Panels and continue to assemble your Select Comfort Sleep System. The Foam Topper Pad will recover its correct shape over a short period of time.

Step 5

- Begin to peel the backing paper and apply the felt strips to each of the 3 center planks.
- Cut off any excess felt when you reach the end of the plank.



Step 6

- Begin to peel the backing paper from a felt strip and apply to the outside edge of a side plank (Hint: apply the strip with half of it hanging over the edge and then fold over and secure on the outside edge.)
- Cut off any excess felt when you reach the end of the plank.
- Repeat this process on the other side plank.

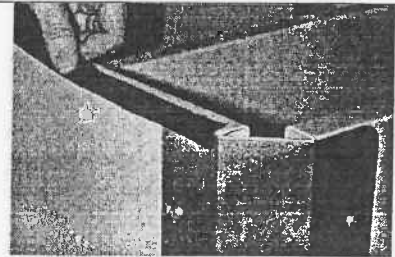

Step 7

- The felt U-clips are placed (3 per side) along the bottom of the side planks.
- Carefully lift the foundation and push each of the three U-clips on each side plank as shown.

Note: If you own a king size bed that uses 2 twin foundations, the clips must be staggered on the side where the two foundations meet to allow a proper fit.

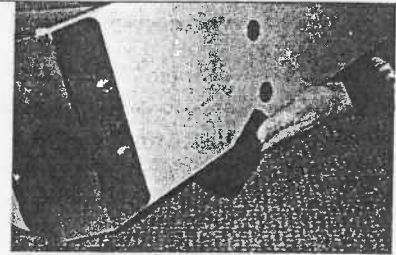

Step 8

- If you have a bed frame with wooden slats, position each U-clip to rest directly on top of a slat.
- Place the foundation on the bed frame and reassemble the bed.

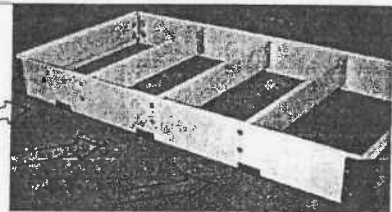

Contact customer service at 1-800-472-7185 if you have questions.

Representatives are available (central time):

Monday - Friday, 7:00 a.m. - 10:00 p.m.

Saturday, 8:00 a.m. - 5:30 p.m.

Sunday, 10:00 a.m. - 6:30 p.m.

Select Comfort Corporation
6105 Trenton Lane North,
Minneapolis, Minnesota 55442
www.selectcomfort.com/comfortclub

5 Fit the Coverlet Over the Foundation

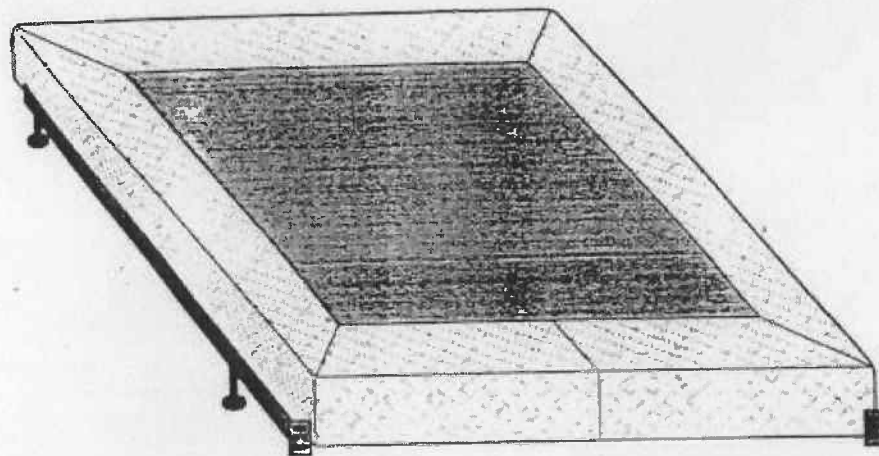

- Take the Coverlet and find the seam on its quilted border wall. This end of the Coverlet covers the head of Foundation.
- Slip the Coverlet completely over the two corners at the head of the Foundation.
- Then pull the Coverlet around the two corners at the foot of the Foundation and adjust each side of the Coverlet for an even appearance.
- You can now begin assembly of your Select Comfort Mattress directly onto your Foundation.

Answers to Commonly Asked Questions:

Q What if the Deck Panels are not lying flat?

A Most likely, one of the End Planks was attached upside down. Check to make sure that both End Planks have been attached with the deep shelf facing up. (Refer to inset in Step 1 for a diagram showing the deep shelf.)

Q What side of the topper pad should face upward?

A The "bumpy" side of the topper pad should face upward.

Q What if my bedframe is too large for my foundation?

A Some bedframes are not adjustable. If your bedframe is too large for your foundation, you may need to use several wooden slats to support the foundation on the frame.